

# XFMRS

## Vertical Mount COMBOS **NEW**

### Electrical Specifications : @25°C

- Isolation Voltage : 1500Vrms (Input to Output)
- Isolation Voltage : 500Vrms (P1+2+3 to P4+5+6)
- Turns Ratio: TX 1CT:1CT ±3% RX 1CT:1CT ±3%
- CABLE SIDE OCL : 350uH Minimum @100KHz 100mV 8mADC
- CABLE SIDE Cw/w : 30pF Max @1MHz 100mV
- CABLE SIDE LL : 0.300uH Max @1MHz 100mV, Short Sec
- DCR : (J6 - J3) = (J2 - J1) 1.2 Ohms Max
- Insertion Loss (100KHz - 100MHz) : -1.10dB Typ
- Return Loss : @1 - 30MHz -18dB Typ  
@60 - 80MHz -12dB Typ
- Cross Talk (1MHz - 100MHz) : -40dB Typ
- Common to Common Mode Attenuation : (30MHz - 100MHz) -35dB Typ
- Rise Time : 1Vpeak Output 3.0nSec Max  
112nSec Pulse Width 3nSec Max

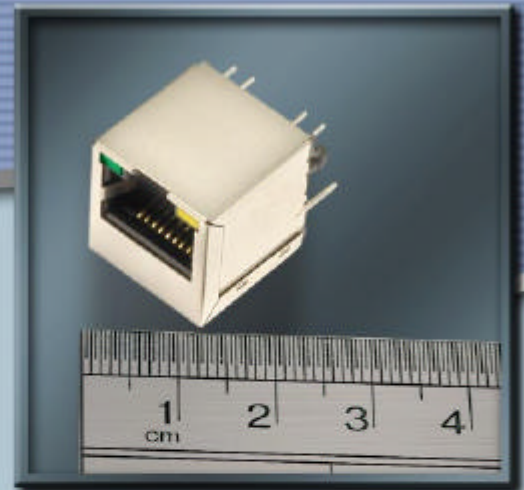

#### Notes:

1. Solderability : Leads shall meet MIL-STD-202G, Method 208H for solderability.
2. Flammability : UL94V-0
3. ASTM oxygen index : >28%
4. Insulation System : Class F 155°C. UL file E151556
5. Operating Temperature Range: All listed parameters are to be within tolerance from -40°C to +85°C
6. Storage Temperature Range: -55°C to +125°C
7. Aqueous wash compatible
8. Electrical and mechanical specifications 100% tested
9. RoHS Compliant Component

### XFATM9-CVxu1-2M

(10/100 Auto-MDIX Compatible)

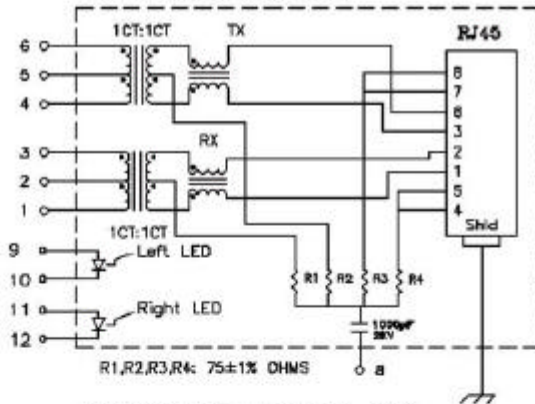

### XFV0IPTVS-LCVxu1-2M

(GR1089 Lightning Protection and POE Capable)

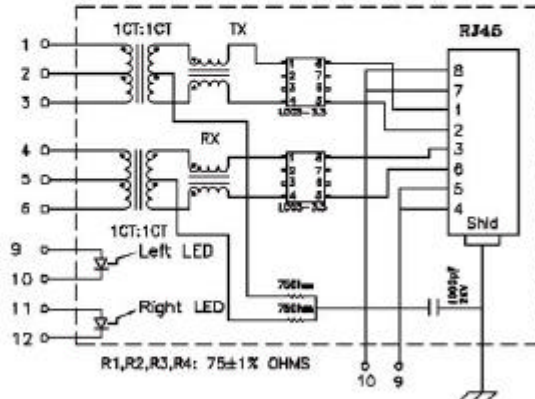

### XFATM9DM-LCVxu1-2M

(GR1089 Lightning Protection)

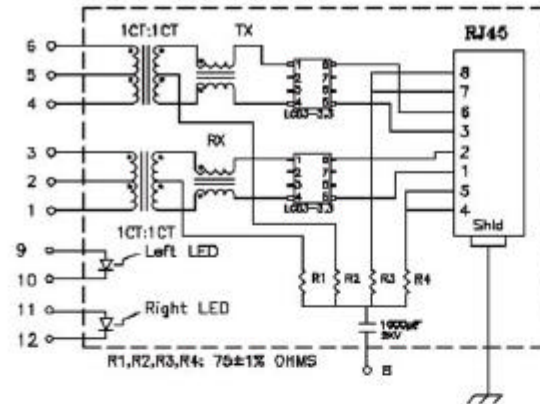

Complete the Combo P/N as follows:

Replace 'x' & 'u' in the part number with one of the LED color letters:

Y=Yellow  
G=Green  
A=Amber  
R=Red  
'x' = Left LED Color  
'u' = Right LED Color

C=Green(1)/Amber(2) Bicolor  
D=Amber(1)/Green(2) Bicolor  
M=Green(1)/Yellow(2) Bicolor  
N=Yellow(1)/Green(2) Bicolor  
P=Red(1)/Green(2) Bicolor  
Q=Green(1)/Red(2) Bicolor  
E=Red(1)/Yellow(2) Bicolor  
F=Yellow(1)/Red(2) Bicolor  
H=Amber(1)/Yellow(2) Bicolor  
J=Green(1)/Green(2) Bicolor

Single Color LED:

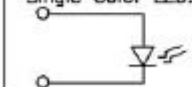

Bi-Color LED:

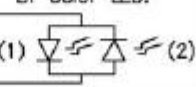

# XFMRS

www.XFMRS.com xfmrsinc@aol.com

**USA**

- 7570 E. Landersdale Road, Camby, Indiana 46113 USA TEL: (317) 834-1066 . FAX: (317) 834-1067

**Europe**

- 4 Gravel Pit Lane, Yarnon, Oxford, U.K. OX5 1PX TEL/FAX: 44 (0) 1865-374690

**Hong Kong**

- Block G,H,I & J, 3/F, Phase 1, Golden Dragon Industrial Centre, 162-160 Tai Lin Pai Road, Kwai Chung, N.T., Hong Kong Tel: (852) 2423-1689 Fax: (852) 2420-3236

### Mechanical Dimensions:

XFATM9DM-LCVxu1-2M  
XFVOIPTVS-LCVxu1-2M

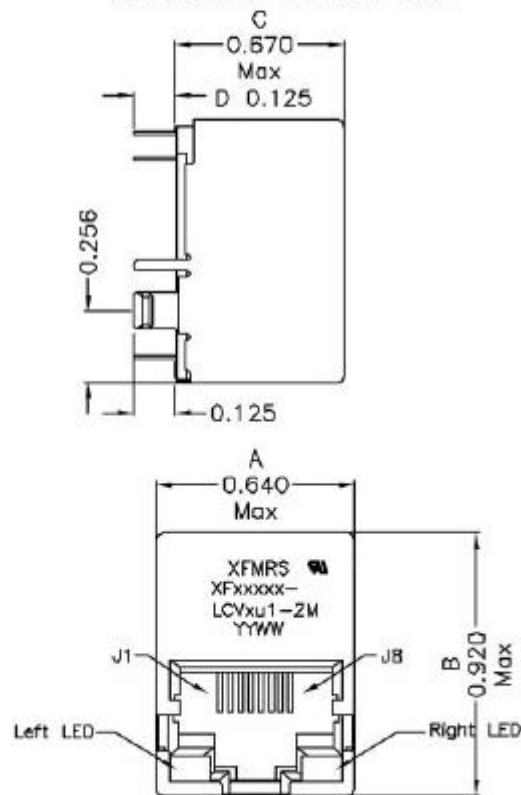

#### Mounting Pattern:

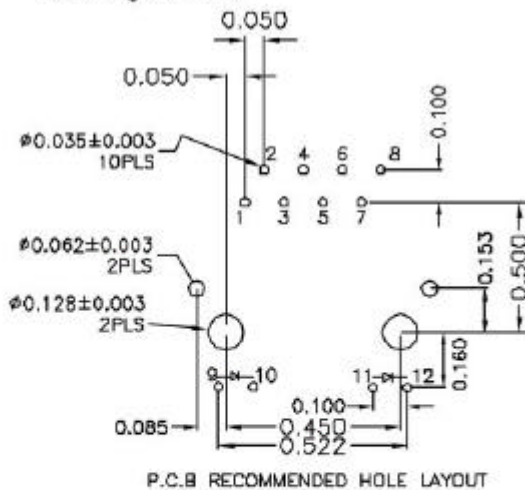

XFATM9-CVxu1-2M

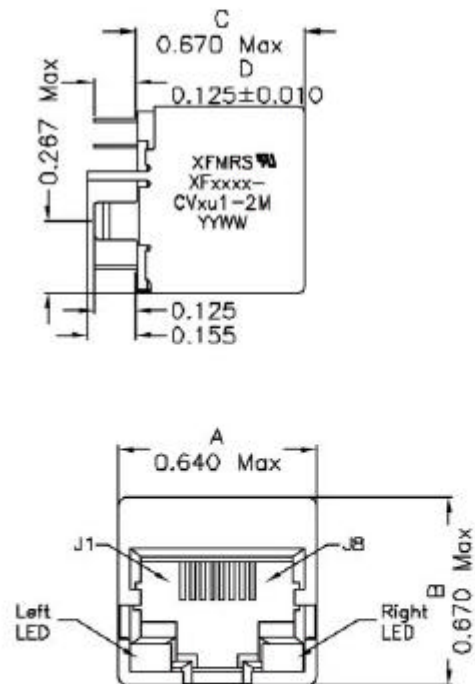

#### Mounting Pattern:

