

1. Mechanical Dimensions:

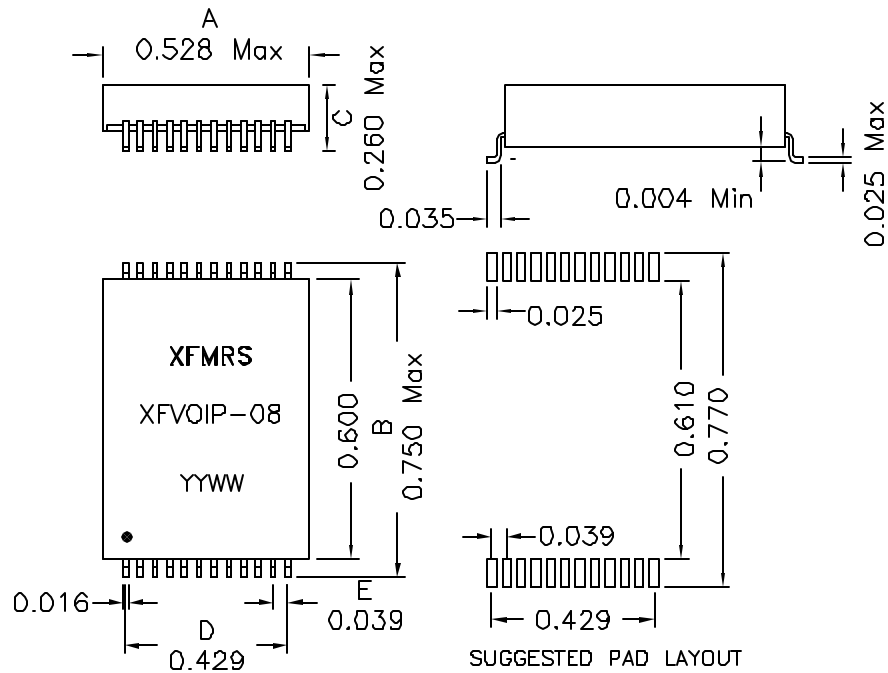

2. Schematic:

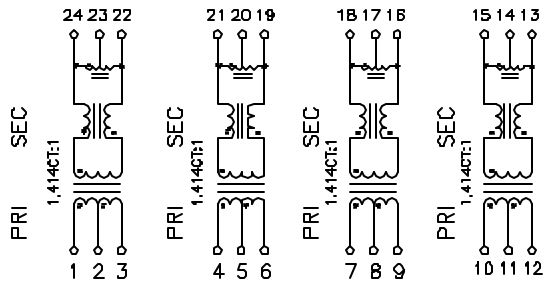

3. Electrical Specifications: @25°C

- ISOLATION: 1500 Vrms
- INSERTION LOSS: -1.1dB Min @1MHz-100MHz
- PRI OCL: 350 uH Min @100KHz 100mV 8mADC
- RETURN LOSS: -16dB Min @1-30MHz
 - 14dB Min @40MHz
 - 13dB Min @50MHz
 - 12dB Min @60-80MHz
- Differential to Common Mode Rejection:
 - 43dB Min @30MHz
 - 37dB Min @60MHz
 - 33dB Min @100MHz
- Crosstalk: -43dB Min @30MHz
 - 37dB Min @60MHz
 - 33dB Min @100MHz

Notes:

- Solderability: Leads shall meet MIL-STD-202, Method 20BD for solderability.
- Flammability: UL94V-0
- ASTM oxygen index: > 28%
- Insulation System: Class F 155°C. UL file E151556
- Operating Temperature Range: -40°C to +85°C

DOC. REV: A/2

XFMRs Inc	Title: VOICE OVER IP MAGNETICS	
	P/N: XFVOIP-08	REV. A
UNLESS OTHERWISE SPECIFIED TOLERANCES: .xxx ±0.010 Dimensions in INCH	DWN.	罗振江 Jul-07-03
	CHK.	廖玉坤 Jul-07-03
SCALE 2:1 SHT 1 OF 1	APP.	Joe Huff Jul-07-03