

1. Mechanical Dimensions:

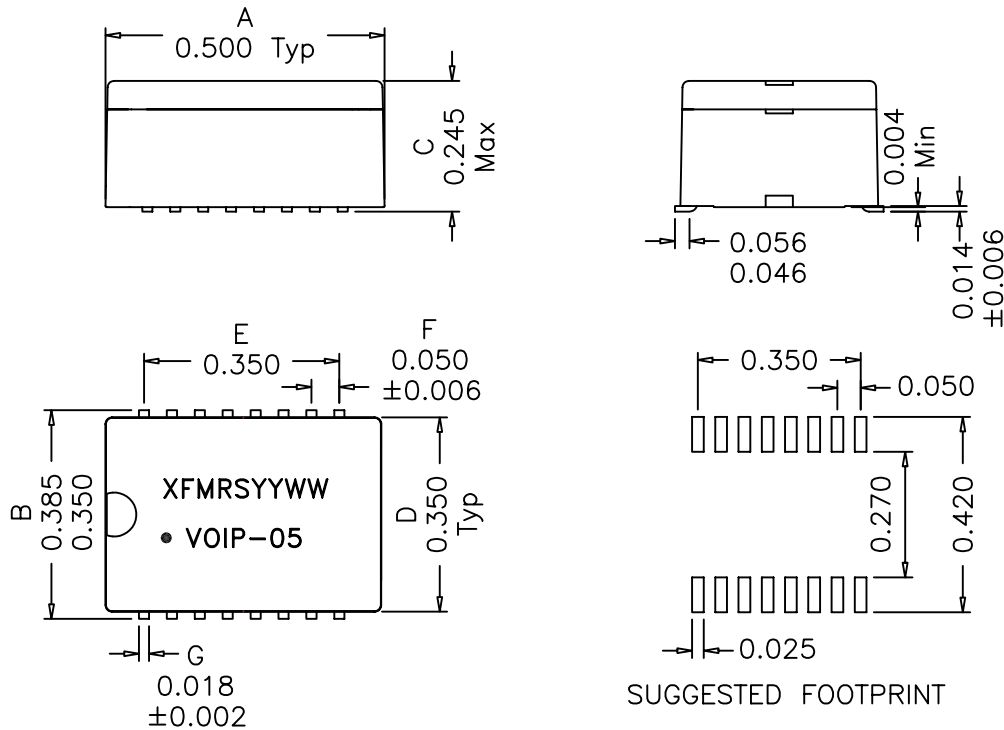

3. Electrical Specifications: @25°C

Isolation Voltage: 1500Vac

OCL: Pins 6-8 350uH Min @100KHz 0.1V, 8mA_{dc}

Pins 1-3 350uH Min @100KHz 0.1V, 8mA_{dc}

Q: Pins 6-8 10 Min @10KHz 50mV

Pins 1-3 10 Min @10KHz 50mV

Insertion Loss: 1.2dB Max @1-100 MHz

Return Loss: (Min @100 Ohms)

1-30MHz	40MHz	50MHz	60-80MHz
-16dB	-14dB	-13dB	-12dB

Differential to Common Mode Rejection: (Min)

30MHz	60MHz	100MHz
-43dB	-37dB	-33dB

Crosstalk: (Min)

30MHz	60MHz	100MHz
-45dB	-40dB	-35dB

DC Current: 350mA

Balanced DC Line Current: 350 mA Max @70V_{dc} continuous

Notes:

- Solderability: Leads shall meet MIL-STD-202G, Method 208H for solderability.
- Flammability: UL94V-0
- ASTM oxygen index: > 28%
- Insulation System: Class F 155°C. UL file E151556
- Operating Temperature Range: All listed parameters are to be within tolerance from -40°C to +85°C
- Storage Temperature Range: -55°C to +125°C
- Aqueous wash compatible
- SMD Lead Coplanarity: ±0.004"(0.102mm)
- Electrical and mechanical specifications 100% tested
- RoHS Compliant Component
- "YY" means year, "WW" means number of week

2. Schematic:

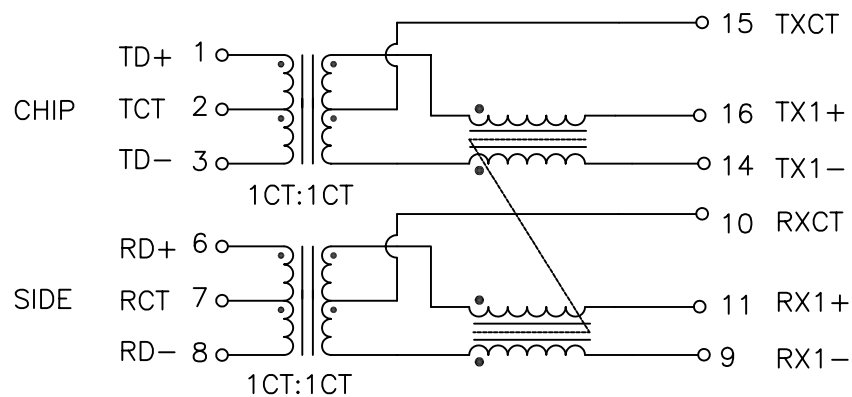

DOC. REV: B/4

XFMRS Inc. www.XFMRS.com	Title: 10/100TX VOICE OVER IP MAGNETICS MODULES		
	UNLESS OTHERWISE SPECIFIED TOLERANCES: .xxx ±0.010 Dimensions in Inch	P/N: XFVOIP-05	REV. B
SHT 1 OF 1	DWN.	Feng	Nov-21-11
	CHK.	YK Liao	Nov-21-11
	APP.	BW	Nov-21-11

PROPRIETARY

Document is the property of XFMRS Group & is not allowed to be duplicated without authorization.