

### 1. Mechanical Dimensions:

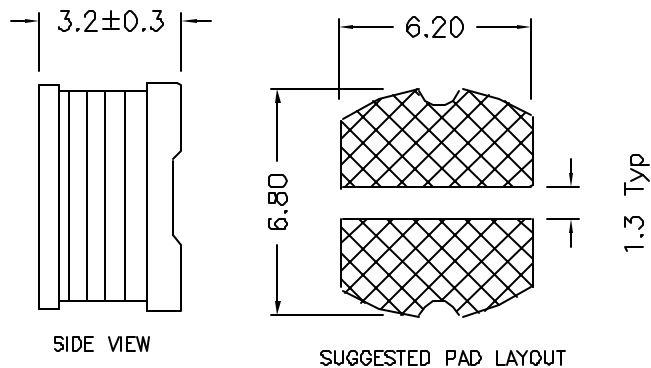
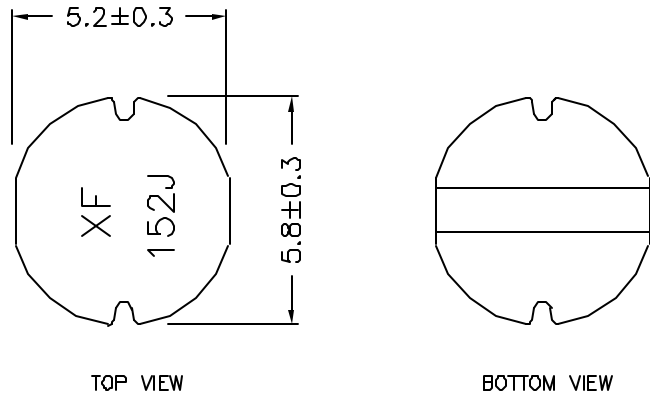

**Notes:**

1. Solderability: Leads shall meet MIL-STD-202, Method 208D for solderability.
2. Flammability: UL94V-0
3. ASTM oxygen index: > 28%
4. Insulation System: Class F 155°C. UL file E151566
5. Operating Temperature Range: All listed parameters are to be within tolerance from -40°C to +85°C
6. Storage Temperature Range: -55°C to +125°C
7. Aqueous wash compatible

DOC REV: A/1

### 2. Schematic:

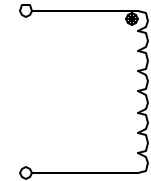

### 3. Electrical Specifications:

OCL: 1500uH±5% @252KHz 0.1V

DCR: 13 Ohms Max

Irms: 0.059A Max (Based on 40°C Temp Rise)

Isat: 0.072A Typ (Based on 10% drop in OCL)

Q: 40 Typ @252KHz

SRF: 2MHz Min

**PROPRIETARY**

Document is the property of XFMRs Group & is not allowed to be duplicated without authorization.

<b>XFMRs Inc</b>	Title: XFSDR53 SERIES INDUCTORS		
	UNLESS OTHERWISE SPECIFIED TOLERANCES: .xx ±0.30 Dimensions in mm	P/N: XFSDR53-152J	REV. A
	DWN.	罗振江	May-19-04
	CHK.	廖玉坤	May-19-04
SHT 1 OF 1	APP.	J Ng	May-19-04