

XFMRS, Inc.

SPECIFICATION FOR APPROVAL

XFMRS P/N : XFEB201209-121-5A Rev: A/1

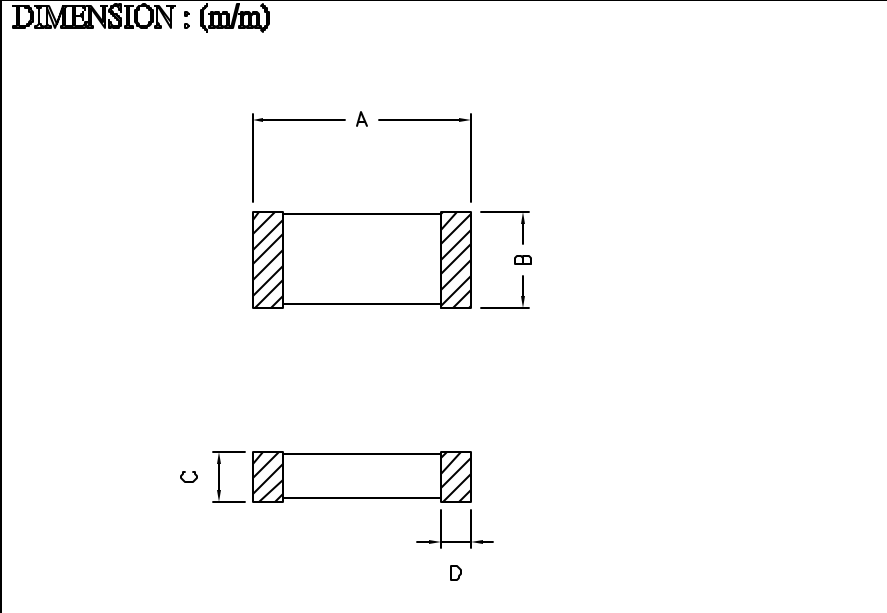

A	Ø2.0±0.2	m/m
B	1.2±0.2	m/m
C	0.9±0.2	m/m
D	0.5±0.3	m/m
E		m/m
F		m/m
G		m/m
H		m/m
I		m/m
J		m/m
K		m/m
L		m/m
M		m/m
N		m/m
O		m/m

ELECTRICAL REQUIREMENTS

TEST INSTRUMENTS

Z	120 Ohms Typ	TEST FREQ.	100	MHz
Z	183 Ohms Typ	TEST FREQ.	500	MHz
Z	152 Ohms Typ	TEST FREQ.	1000	MHz
R _{dc}	0.020 Ohms Max	TEST FREQ.		MHz
I _{dc}	5000mA Max	TEST FREQ.		MHz

- HP 34401A MULTIMETER
- HP 4195 NETWORKS/SPECTRUM ANALYZER
- HP 42841 BIAS CURRENT SOURCE
- HP 4285A LCR METER
- HP 4286A RF LCR METER
- HP 4291A RF IMPEDANCE / MATERIAL ANALYZER
- HP 4338A MILLION OHM METER
- HP 6632A DC POWER SUPPLY
- HP4284A PRECISION LCR METER

- Notes:**
- Solderability: Leads shall meet ML-STD-202, Method 2080 for solderability.
 - Flammability: UL94V-0
 - ASTM oxygen index: > 28%
 - Insulation System: Class F 155°C, UL file E191356
 - Operating Temperature Range: All listed parameters are to be within tolerance from -55°C to +125°C
 - Storage Temperature Range: -55°C to +125°C
 - Aqueous wash compatible

DRAWN BY :

BW

CHECKED BY :

TONY
IMBURGIA

APPROVED BY :

JOE HUFF 4-07-04