

1. Dimensions:

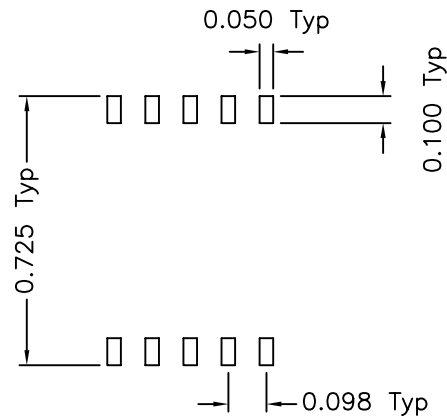

Suggested PCB Layout

2. Schematic:

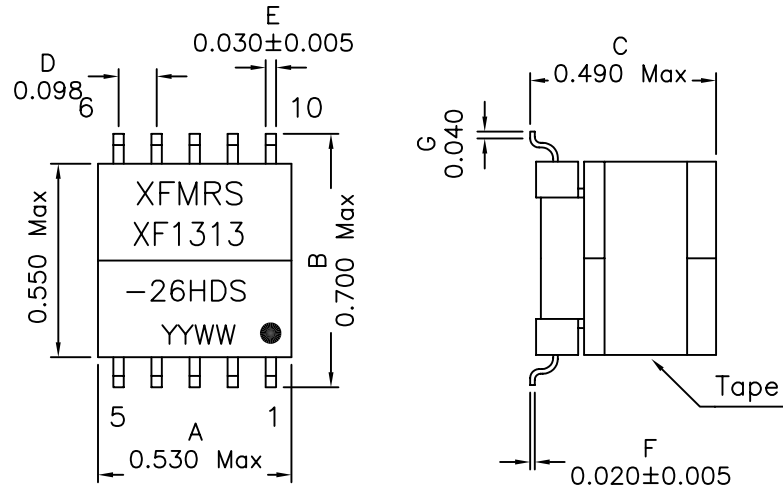
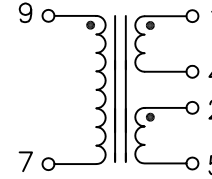

3. Electrical Specifications: @25°C

OCL: Pins 1-5 3.0mH ±6% @10KHz 0.1V, 0mA, Tie Pins 2-4

LL: Pins 1-5 15uH Max @100KHz 0.1V, Tie Pins 2-4, Short Pins 9-7

CW/W: Pins 9-1 150pF Max @100KHz 0.1V, Tie Pins 2-4

TURNS RATIO: Pins (9-7):(1-5)=1:5.4CT±2%, Tie Pins 2-4

DC Res.: Pins 9-7 0.350 Ohms Max

DC Res.: Pins 2-5 2.10 Ohms Max

DC Res.: Pins 1-4 2.10 Ohms Max

ISOLATION VOLTAGE: 1500Vrms (Chip to Line)

ISOLATION VOLTAGE: 600Vrms (Line to Line)

RETURN LOSS: 15dB Min @40-500KHz

LONGITUDINAL BALANCE: 55dB Min @20-500KHz

THD: -79db Max @5KHz 4Vrms

Notes:

- Solderability: Leads shall meet MIL-STD-202, Method 208D for solderability.
- Flammability: UL94V-0
- ASTM oxygen index: > 28%
- Insulation System: 155°C. UL file E151556
- Operating Temperature Range: -40°C to +85°C
- Designed to meet UL 60950, IEC 60950, and GR1089 for Supplementary Insulation requirements for working voltages up to 250Vrms.

DOC. REV A/4

XFMRS Inc	Title: HDSL TRANSFORMER	
	P/N: XF1313-26HDS	REV. A
UNLESS OTHERWISE SPECIFIED TOLERANCES: .xxx ±0.010 Dimensions in INCH	DWN.	廖玉坤 Feb-11-03
	CHK.	李清儿 Feb-11-03
SHEET 1 OF 1	APP.	Isaiah M Feb-11-03