

1. Dimensions:

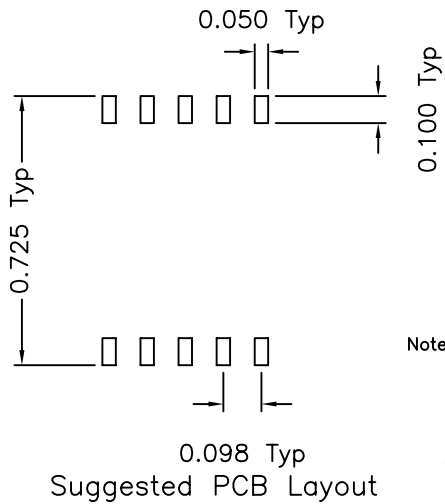
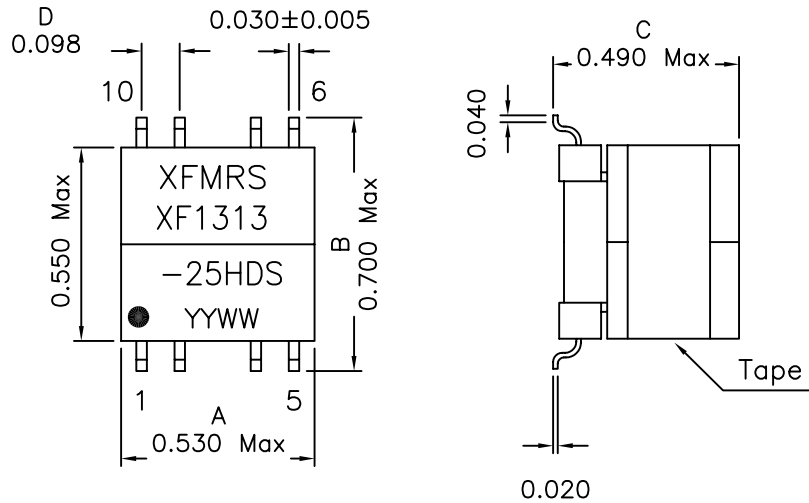

Notes:

1. Solderability: Leads shall meet MIL-STD-202, Method 208D for solderability.
2. Flammability: UL94V-0
3. ASTM oxygen index: > 28%
4. Insulation System: Class F 155°C. UL file E151556
5. Operating Temperature Range: -40°C to +85°C
6. Storage Temperature Range: -55°C to +125°C
7. Aqueous wash compatible

2. Schematic:

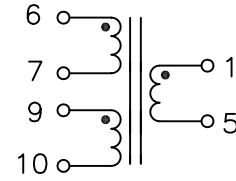

3. Electrical Specifications: @25°C

PIN6-10 OCL: 4.08mH ±15% @10KHz 0.1V 0/100mAdc
(CONNECT PIN7-9)

PIN6-10 LL: 12uH Max @100KHz 100mV
(CONNECT PIN7-9 and PIN1-5)

PIN6-1 Cww: 130pF Max @10KHz, 0.1V

URNS RATIO: 6-7:9-10:1-5 = 1.15:1.15:1

DC Res.: P6-7 1.10 Ohms Typ

DC Res.: P9-10 1.10 Ohms Typ

DC Res.: P1-5 1.0 Ohms Typ

Return Loss: with 135 Ohms load

16dB Min @25KHz

20dB Min @40KHz

22dB Min @292KHz

14dB Min @1MHz

Insertion Loss: 0.5dB Min @292KHz, 135 Ohms Load

Isolation Voltage; 2000Vac, Pri to Sec

Isolation Voltage; 500Vac, Pri to Pri

DOC. REV A/1

XFMRS Inc	Title: HDSL TRANSFORMER			
	UNLESS OTHERWISE SPECIFIED TOLERANCES: .xxx ±0.010 Dimensions in INCH		P/N: XF1313-25HDS	REV. A
	DWN.	廖玉坤	Jul-31-02	
	CHK.	李清儿	Jul-31-02	
SHEET 1 OF 1	APP.	BW	Jul-31-02	