

# XFMRs

## XF100910DL Series Power Inductors for Class D Digital Audio Amplifiers

- \* Compact Size
- \* High DC Current Capability
- \* Low DC Resistance
- \* RoHS Compliant
- \* Tape and Reel Packaging Standard
- \* Applications Include: TVs, Car Audio, Home Theater, etc...

### Mechanical Characteristics:

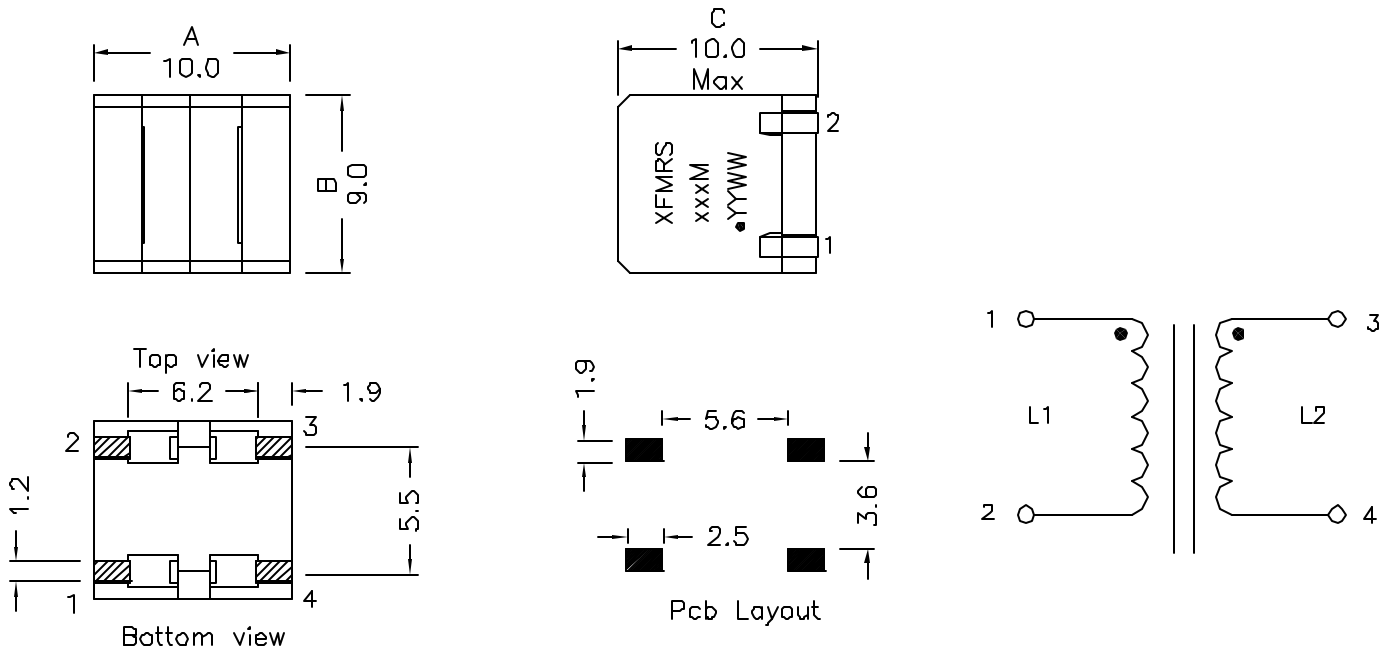

### Electrical Characteristics:

Part Number	INDUCTANCE (uH)±20%	DCR (mOhms) Max	Isat (Adc)	Heating Current (Adc)
XF100910DL-100M	10.0	22.0	3.90	5.00
XF100910DL-120M	15.0	25.0	3.40	4.30
XF100910DL-150M	15.0	44.0	2.80	4.10
XF100910DL-220M	22.0	52.0	2.50	3.20

Notes:

1. Solderability: Leads shall meet MIL-STD-202G, Method 208H for solderability.
2. Flammability: UL94V-0
3. ASTM oxygen index: > 28%
4. Insulation System: Class F 155°C. UL file E151556
5. Operating Temperature Range: All listed parameters are to be within tolerance from -40°C to +85°C
6. Storage Temperature Range: -55°C to +125°C
7. Aqueous wash compatible
8. SMD Lead Coplanarity: ±0.004"(0.102mm)
9. Electrical and mechanical specs 100% tested
10. RoHS Compliant Component