

1. Mechanical Dimensions:

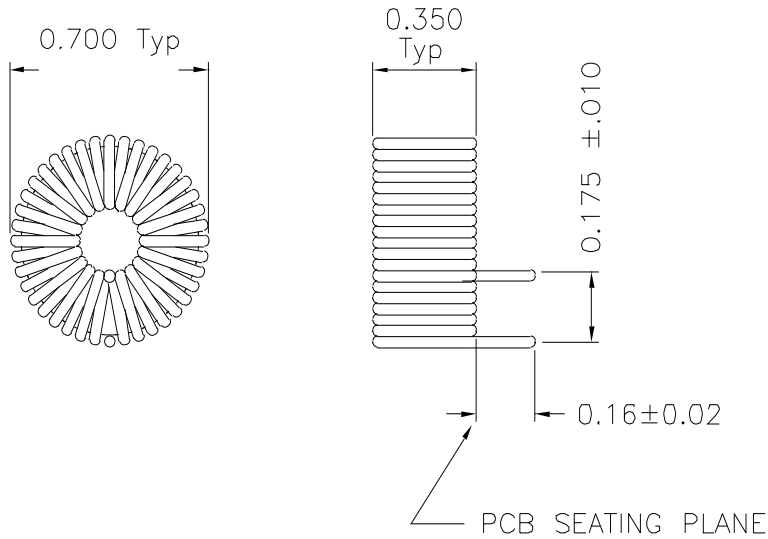

Note:

The tinned length is the same as the Lead length

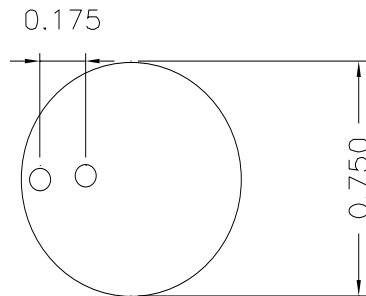

Suggested PCB Layout

2. Schematic:



3. Electrical Specifications: @25°C

Inductance: 61uH ±20% @ 10KHz, 0.1V

OCL: 40uH Typ @ 10KHz, 0.1V 3Adc

DC Res.: 0.050 Ohms Max

DOC. REV A/1

XFMRs Inc	Title: TOROIDAL INDUCTOR		
	UNLESS OTHERWISE SPECIFIED TOLERANCES: N/A		REV. A
	P/N: 1XF0075-HO	DWN.	李清儿 Aug-19-99
	Dimensions in INCH	CHK.	孙怡 Aug-19-99
SHEET 1 OF 1	APP.	Joe Huff Aug-19-99	